

SWITCHGEAR...

- 2 - 5 ▶ DC HIGH CURRENT ISOLATOR
DC HIGH CURRENT LOAD BREAKER
JUMPER SWITCH ISOLATOR
- 6 - 7 ▶ DC SHORT CIRCUIT SWITCH
SHORT CIRCUIT FRAME
MOBILE DC SHORT CIRCUIT SWITCH
- 8 - 9 ▶ SWITCHGEARS FOR TRACTION
- 10 - 11 ▶ LOW VOLTAGE AND MEDIUM
VOLTAGE SWITCHGEARS

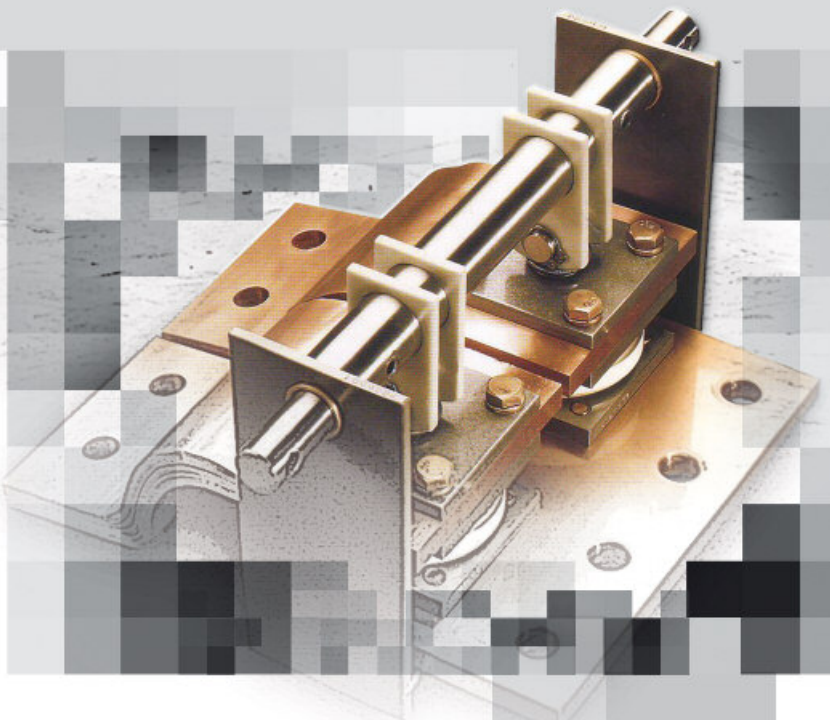

FLOHE DC HIGH CURRENT ISOLATOR

THE MODULAR STRUCTURE CORRESPONDS TO THE HIGHEST MECHANICAL AND ELECTRICAL STANDARDS.

Type FRH has a visible isolating distance and regardless of the position, can be vertically or horizontally welded or screwed into the busbar system.

The isolator has incoming and outgoing aluminium contact blocks or copper contact blocks which are provided for welding or screwing to the existing busbar system. An additional wall support is not necessary. The isolator is supported by the busbar package. Shifts to the busbars are compensated in three directions.

A flexible spring adjustment system ensures a secure electrical and mechanical contact and the silver plated main contacts ensure a low voltage drop.

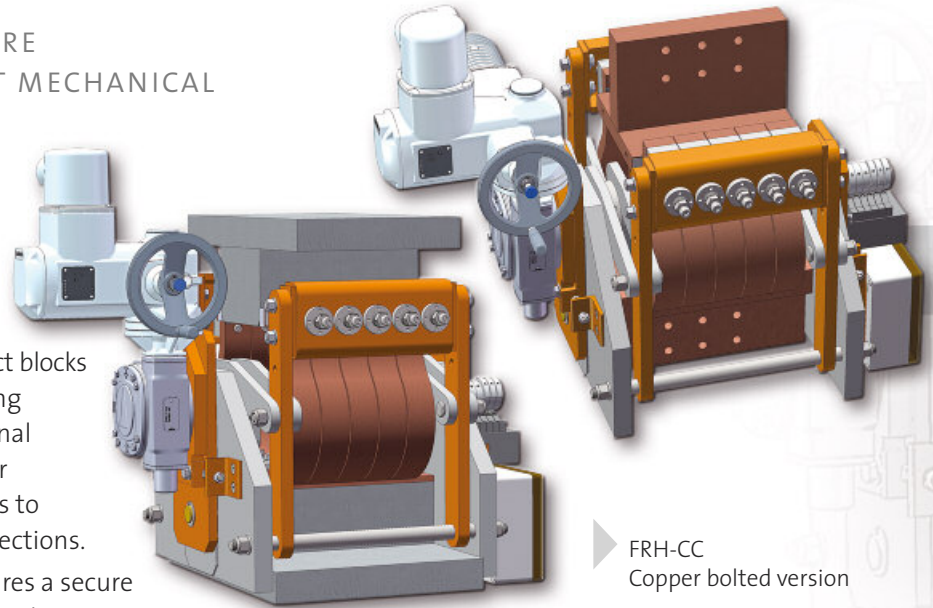

FRH TYPES CAN BE SUPPLIED IN ALL NEEDED VERSIONS

- Manual / motor pneumatic
- Remote drive / emergency drive
- Panic switch function
- Auxiliary switch for internal and external control
- Locking systems: mechanical or electrical
- Terminal box: local / or remote control box
- Temperature monitoring

TECHNICAL DATA

TECHNICAL DATA	Standard units
max. nominal current	400 kA
max. nominal voltage	3000 V
Peak short circuit current	10x nominal current 1 s
Insulation voltage	5000 V DC
max. ambient temperature	60°C
max. temperatur rise	max. ambient temp. +40°C
Operating time ON OFF	motor less 20s / pneumatic less 1s
Traversing in (x/y/z) direction	± 20 mm
mechanical lifespan	5000 operations

Custom design upon request

Type	Current [kA]	Assembling	Dimension													
			Contact adapter A			Contact adapter B			C	D	E	F		G		H
			A1 standard	A2 standard	A3 standard	B1 standard	B2 standard	B3 standard				closed ON	open OFF approx. [mm]	closed ON approx. [mm]	open OFF approx. [mm]	
min. [mm]	[mm]	min. [mm]	min. [mm]	[mm]	min. [mm]	[mm]	standard	standard	standard	[mm]	[mm]	standard	standard	[mm]		
FRH-CC	15	1x15	180	50	190	260	50	167	400	475	783	226	326	559	646	617
FRH-CC	20	1x20	230	50	190	310	50	167	450	475	833	226	326	559	646	617
FRH-CC	25	1x25	280	50	190	360	50	167	500	475	883	226	326	559	646	617
FRH-CC	30	1x30	330	50	190	410	50	167	550	475	933	226	326	559	646	617
FRH-CC	35	1x35	380	50	190	460	50	167	600	475	983	226	326	559	646	617
FRH-CC	40	1x40	430	50	190	510	50	167	650	475	1033	226	326	559	646	617
FRH-CC	45	1x45	480	50	190	560	50	167	700	475	1083	226	326	559	646	617
FRH-CC	50	1x50	530	50	190	610	50	167	750	475	1133	226	326	559	646	617
FRH-CC	55	1x55	580	50	190	660	50	167	800	475	1183	226	326	559	646	617
FRH-CC	60	1x60	630	50	190	710	50	167	850	475	1233	226	326	559	646	617
FRH-CC	70	1x70	730	50	190	810	50	167	950	475	1333	226	326	559	646	617
FRH-CC	80	1x80	830	50	190	910	50	167	1050	475	1433	226	326	559	646	617
FRH-CC	90	1x90	930	50	190	1010	50	167	1150	475	1533	226	326	559	646	617
FRH-CC	100	1x100	1030	50	190	1110	50	167	1250	475	1633	226	326	559	646	617
FRH-CC	110	1x110	1130	50	190	1210	50	167	1350	475	1733	226	326	559	646	617
FRH-CC	120	1x120	1230	50	190	1310	50	167	1450	475	1833	226	326	559	646	617
FRH-CC	130	2x65	1470	50	190	1550	50	167	1690	475	2073	226	326	559	646	617
FRH-CC	140	2x70	1570	50	190	1650	50	167	1790	475	2173	226	326	559	646	617
FRH-CC	150	2x75	1670	50	190	1750	50	167	1890	475	2273	226	326	559	646	617
FRH-CC	160	2x80	1770	50	190	1850	50	167	1990	475	2373	226	326	559	646	617
FRH-CC	180	2x90	1970	50	190	2050	50	167	2190	475	2573	226	326	559	646	617
FRH-CC	200	2x100	2170	50	190	2250	50	167	2390	475	2773	226	326	559	646	617

Other designs upon request · E + G + H = external dimension · all engine-driven designs with manual panic switch function

TYPE FRH

DC HIGH CURRENT ISOLATOR FRH 5 kA · 400 kA · SINGLE-DOUBLEPOLE

FOR CURRENTLESS SWITCHING IN DC SYSTEMS
VDE 0110 GROUP C · EN 60947-3 · IEC 60077-1

FLOHE DC High current Isolator FRH is universally as...

■ **FRH-AA**
Aluminium
welded version

■ **FRH-CC**
Copper
bolted version

■ **FRH-AC**
Combination
Al/Cu

■ **FRH-MO**
Mobile for
graphite plants

▶▶ FRH-AA ◀◀

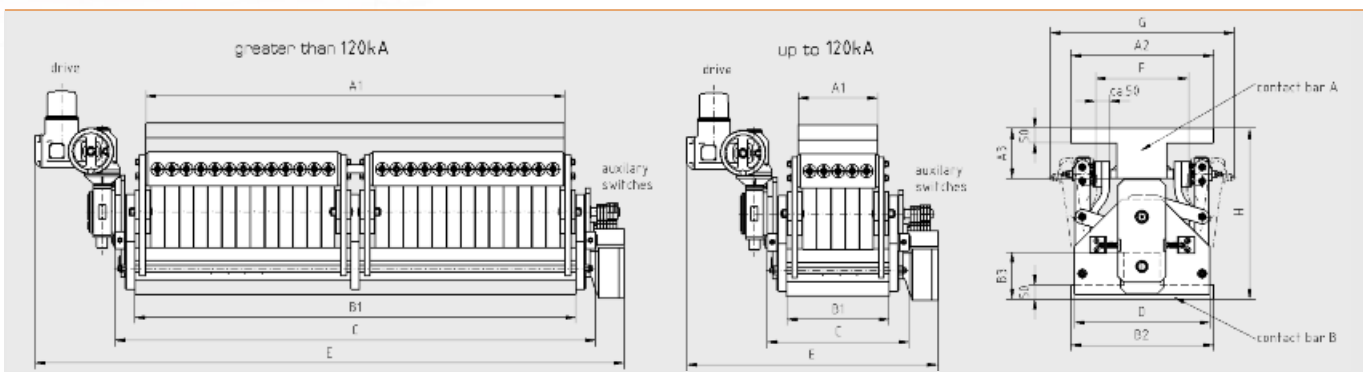

Type	Current [kA]	Assembling	Dimension													
			Contact adapter A			Contact adapter B			C standard	D standard	E standard	F		G		H standard
			A1 standard	A2 standard	A3 standard	B1 standard	B2 standard	B3 standard				closed ON	open OFF approx. [mm]	closed ON approx. [mm]	open OFF approx. [mm]	
min. [mm]	[mm]	min. [mm]	min. [mm]	[mm]	min. [mm]	[mm]	[mm]	[mm]	[mm]	[mm]	[mm]	[mm]	[mm]			
FRH-AA	15	1x 15	180	500	175	260	500	165	400	475	783	226	326	559	646	600
FRH-AA	20	1x 20	230	500	175	310	500	165	450	475	833	226	326	559	646	600
FRH-AA	25	1x 25	280	500	175	360	500	165	500	475	883	226	326	559	646	600
FRH-AA	30	1x 30	330	500	175	410	500	165	550	475	933	226	326	559	646	600
FRH-AA	35	1x 35	380	500	175	460	500	165	600	475	983	226	326	559	646	600
FRH-AA	40	1x 40	430	500	175	510	500	165	650	475	1033	226	326	559	646	600
FRH-AA	45	1x 45	480	500	175	560	500	165	700	475	1083	226	326	559	646	600
FRH-AA	50	1x 50	530	500	175	610	500	165	750	475	1133	226	326	559	646	600
FRH-AA	55	1x 55	580	500	175	660	500	165	800	475	1183	226	326	559	646	600
FRH-AA	60	1x 60	630	500	175	710	500	165	850	475	1233	226	326	559	646	600
FRH-AA	70	1x 70	730	500	175	810	500	165	950	475	1333	226	326	559	646	600
FRH-AA	80	1x 80	830	500	175	910	500	165	1050	475	1433	226	326	559	646	600
FRH-AA	90	1x 90	930	500	175	1010	500	165	1150	475	1533	226	326	559	646	600
FRH-AA	100	1x 100	1030	500	175	1110	500	165	1250	475	1633	226	326	559	646	600
FRH-AA	110	1x 110	1130	500	175	1210	500	165	1350	475	1733	226	326	559	646	600
FRH-AA	120	1x 120	1230	500	175	1310	500	165	1450	475	1833	226	326	559	646	600
FRH-AA	130	2x 65	1470	500	175	1550	500	165	1690	475	2073	226	326	559	646	600
FRH-AA	140	2x 70	1570	500	175	1650	500	165	1790	475	2173	226	326	559	646	600
FRH-AA	150	2x 75	1670	500	175	1750	500	165	1890	475	2273	226	326	559	646	600
FRH-AA	160	2x 80	1770	500	175	1850	500	165	1990	475	2373	226	326	559	646	600
FRH-AA	180	2x 90	1970	500	175	2050	500	165	2190	475	2573	226	326	559	646	600
FRH-AA	200	2x 100	2170	500	175	2250	500	165	2390	475	2773	226	326	559	646	600

Other designs upon request · E + G + H = external dimension · all engine-driven designs with manual panic switch function

FLOHE DC HIGH CURRENT ISOLATOR / DC HIGH CURRENT LOAD BREAKER

THE **FRGL (6-36 kA)** HAS BEEN INCLUDED IN THE RANGE FOR THE TASK OF BI-POLAR MEMBRANE CHLORINE ELECTROLYSIS. IT FEATURES A **PRE-CONTACT** FOR SWITCHING UNDER LOAD (UP TO 750 V DC).

EFRG isolator and FRGL load breaker combinations have been used by industries in many bipolar membrane chlorine electrolysis plants. A control unit with reverse locking is available upon request.

The FRG and FRGL isolators can be supplied for copper designs or aluminium designs. They can be securely supported just by the busbar package and do not require wall support.

Fastening brackets can be supplied on request.

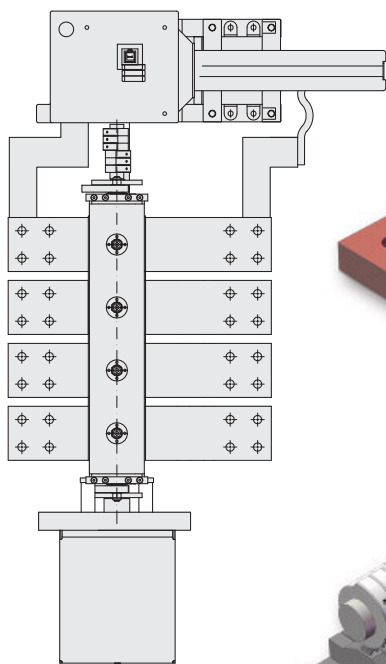

DC Load breaker
FRGL-M-CC
24 kA

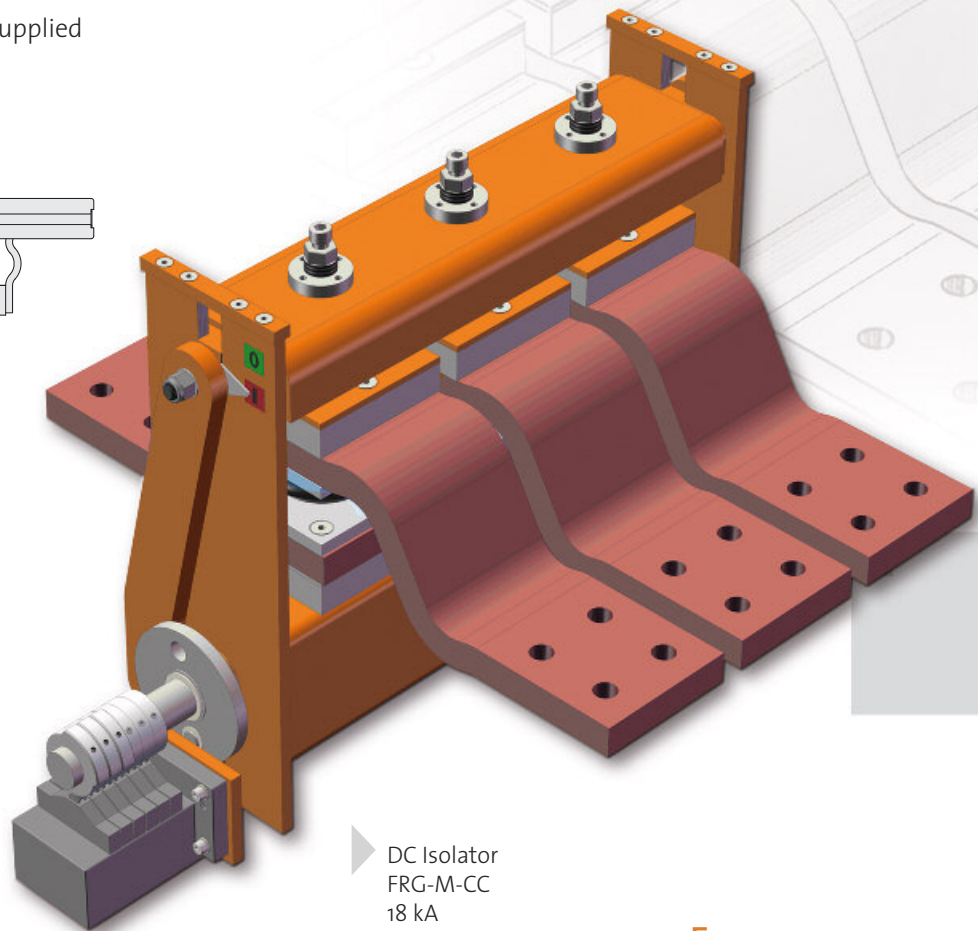

DC Isolator
FRG-M-CC
18 kA

TECHNICAL DATA	FRG	FRGL
max. nominal current	120 kA	36 kA
max. nominal voltage	3000 V	3000 V
max. switching voltage	./.	750 V
Peak short circuit current	10x nominal current 1 sec	10x nominal current 1 sec
Insulation resistance	5.000 V DC	5.000 V DC
max. ambient air temperature	60°C	60°C
max. operating temperature	max. ambient temp. + 40°C	max. ambient temp. + 40°C
mechanical switching cycle	10.000	10.000

Individual specifications upon request

EQUIPMENT...

- Manual / motor pneumatic
- Direct or remote drive
- Pre contact
- Auxiliary switches on request
- Terminal box
- Temperature monitor
- Earthing contact
- Locking system (electrical/mechanical)
- Local or remote control box
- Mechanical indicator "ON / OFF"

FRG / FRGL

FRG-M-CC MOT

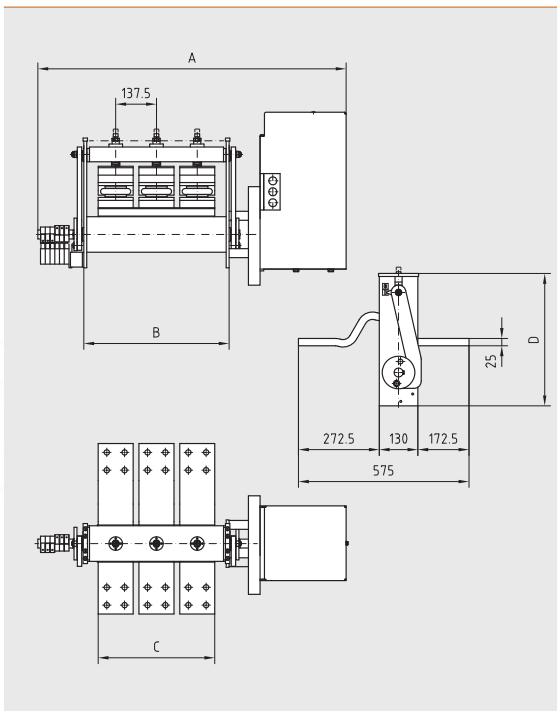

FRG-D-CC MOT

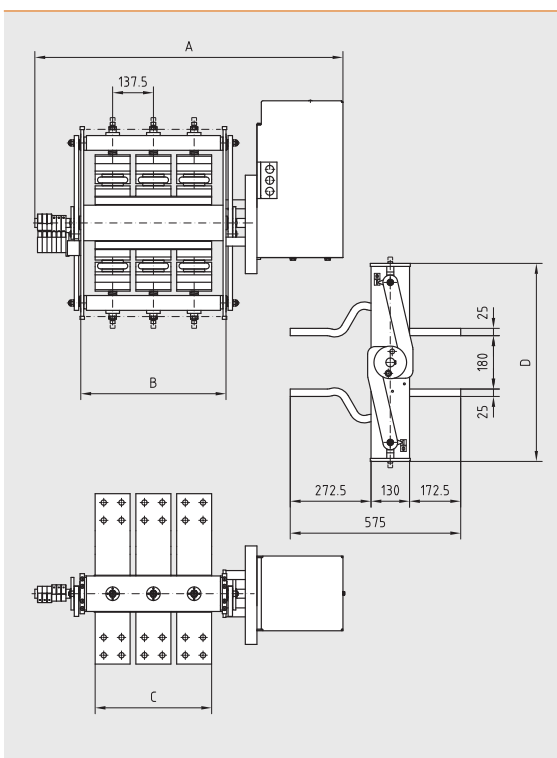

DC HIGH CURRENT ISOLATOR

FRG 6 kA UP TO 120 kA

DC HIGH CURRENT LOAD BREAKER

FRGL 5 kA UP TO 30 kA

THE ENCAPSULATED FRG AND FRGL ISOLATORS ARE A LOGICAL DEVELOPMENT IN VACUUM TECHNOLOGY WITH A CORRESPONDING DISTANCE BETWEEN THE CONTACTS IN ACC. WITH THE VDE + IEC STANDARDS.

The frame is designed for the isolator construction of the vacuum short circuit device. Standard sizes range from 6 kA to 120 kA; larger units are available on request.

The integrated encapsulated main contacts in the isolators have proved their value in corrosive chemical environments and also in terms of their low maintenance, which results in significant cost reductions. The FRG isolators can be screwed / welded into the systems, regardless of position.

Upon request, the FRG can be equipped with an earthing contact, a temperature sensor, a pre-contact for residual current or electrical / mechanical locking.

As standard, the wiring of the auxiliary switch, the motor etc. takes place on a closed terminal box. Upon consultation, full in-house (local) control / remote control are available on a customised basis.

Type	Current max. [kA]	Assem- ling	Dimension			
			A standard [mm]	B standard [mm]	C standard [mm]	D standard [mm]
FRG-M-CC	6	1xM	765	215	118	446.5
FRG-M-CC	12	1xM	902.5	352.5	255.5	446.5
FRG-M-CC	18	1xM	1040	490	393	446.5
FRG-M-CC	24	1xM	1177.5	627.5	530.5	446.5
FRG-D-CC	24	1xD	902.5	352.5	255.5	668
FRG-M-CC	30	1xM	1315	765	668	446.5
FRG-D-CC	36	1xD	1040	490	393	668
FRG-D-CC	48	1xD	1177.5	627.5	530,5	668
FRG-D-CC	60	1xD	1315	765	668	668
FRG-D-CC	72	1xD	1452.5	902.5	805.5	668
FRG-D-CC	96	2xD48	1955	1405	1308	668
FRG-D-CC	120	2xD60	2230	1680	1583	668

Individual customise designs upon request

FLOHE DC SHORT CIRCUIT SWITCH / DC HIGH CURRENT ISOLATOR

THE VACUUM CONTACTS ARE INTEGRATED IN A SWITCHING FRAME (STEEL OR STAINLESS STEEL).

This results in short circuit devices with sizes ranges from 6-400 kA with switching voltages ranging from 5 V DC - 30 V DC.

In atmospheres where there is exposure to harsh chemicals, the vacuum contacts are protected against external aggressive influences and ensure a long maintenance-free service lifespan.

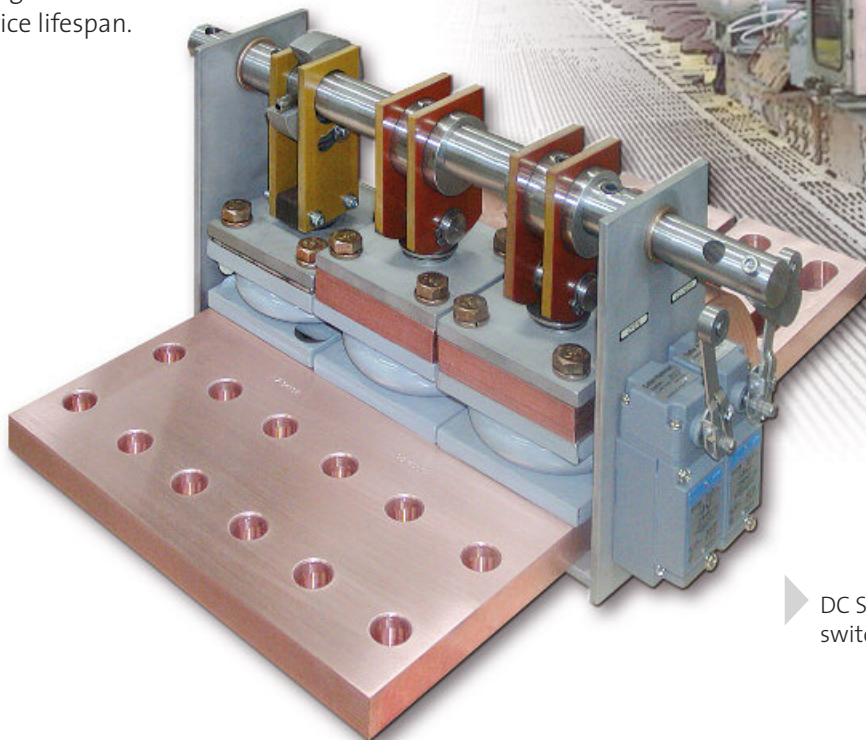

IN COOPERATION WITH



Short circuit frame
copper electroanalysis

DC Short circuit
switch 18 kA

INSTALLATION OPTIONS...

FIXED INSTALLATION
at cell bottom
or into busbar system

■ TYPE VAC 6-400 kA

MOBILE
(JUMPER SWITCHES)
on wheels or crane

■ TYPE VAC-MO 50-250 kA

MOBILE
SHORT CIRCUIT FRAME
for copper electrolysis

■ TYPE VAC-FR 30-70 kA

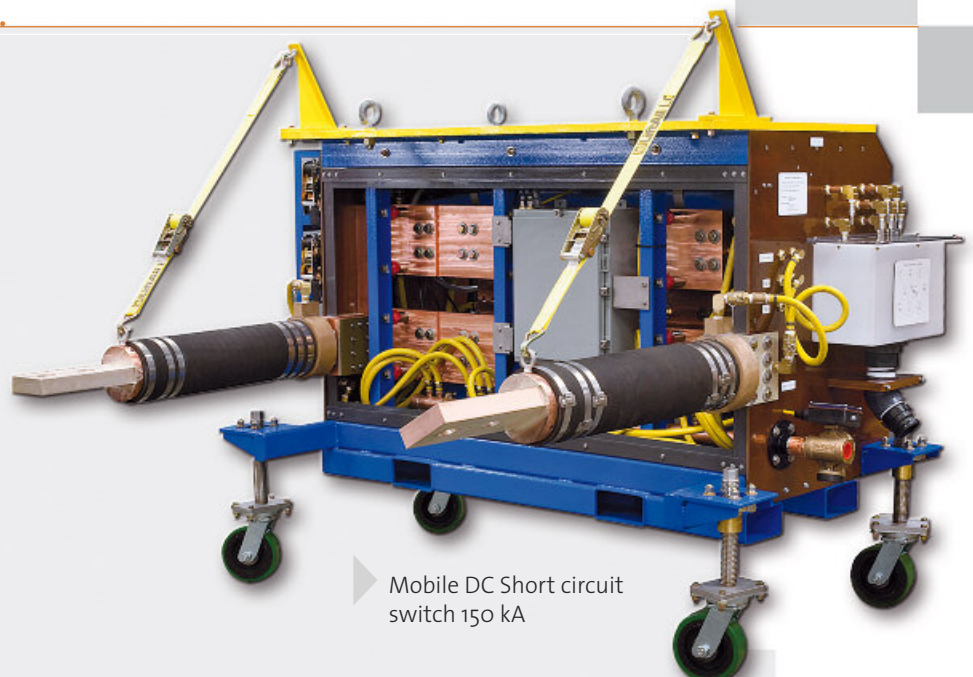

Mobile DC Short circuit
switch 150 kA

VACUUM CONTACT



ENCAPSULATED VACUUM CONTACT

FIXED INSTALLATION OR MOBILE

Watteredge vacuum contact is a patented encapsulated main contact suitable for a short, circuit, switches and DC isolator in electrolysis e.g. Chlorine · copper · nickel · magnesium · aluminium · cobalt · chrome

▶ Vacuum contacts 6 kA

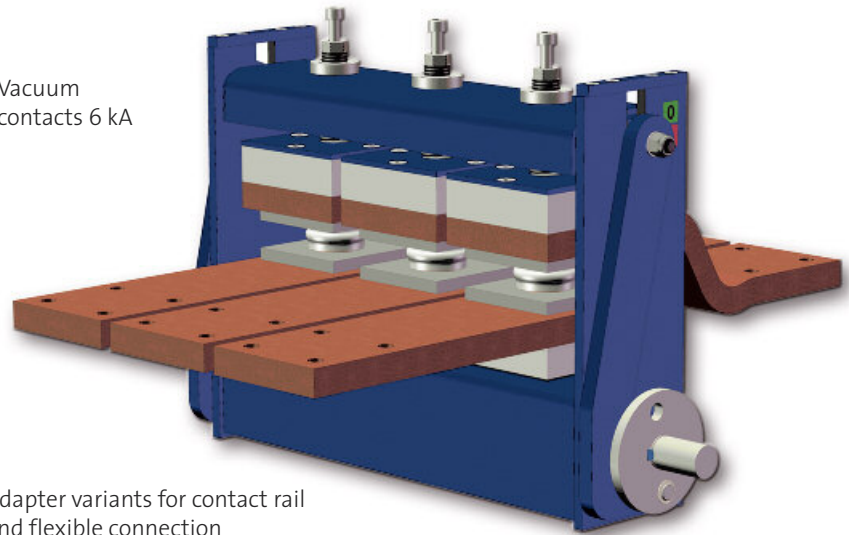

▶ Adapter variants for contact rail and flexible connection

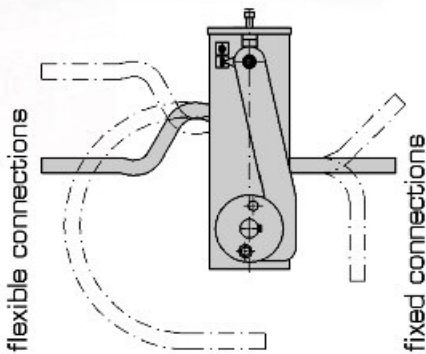

▶▶ SINGLE CONTACT UNIT ◀◀

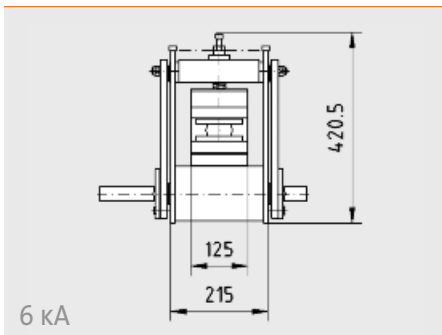

▶▶ DOUBLE CONTACT UNIT ◀◀

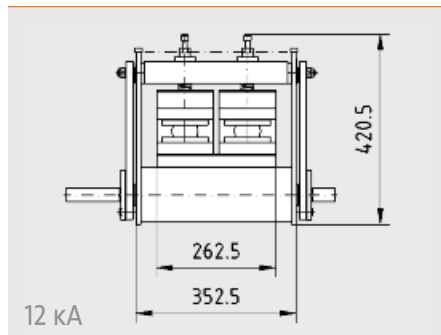

▶▶ TRIPLE CONTACT UNIT ◀◀

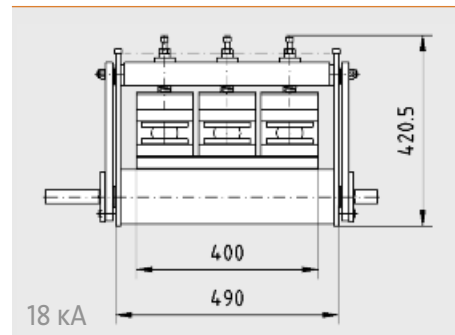

▶▶ QUADRUPLE CONTACT UNIT ◀◀

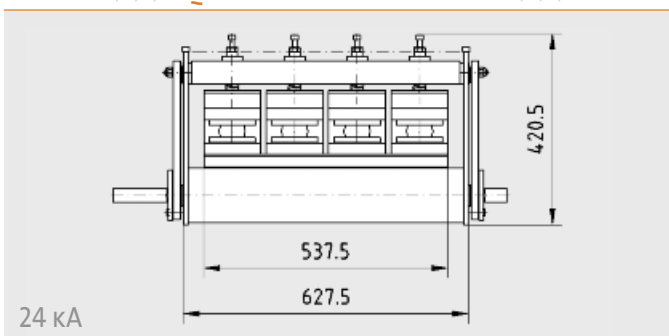

▶▶ FIVE FOLD CONTACT UNIT ◀◀

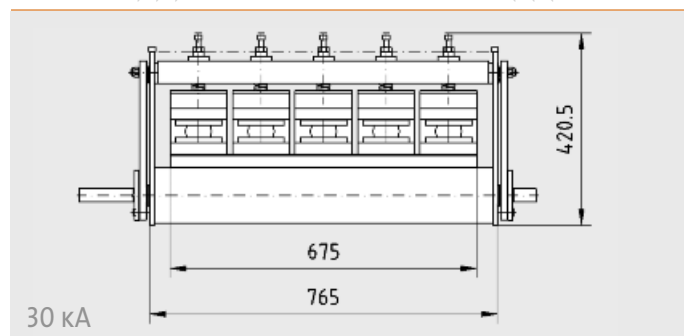

SWITCHGEARS FOR TRACTION

IN RAILWAY SYSTEMS CIRCUIT BREAKERS ARE REQUIRED TO ISOLATE AND EARTH CURRENTS. THESE CIRCUIT BREAKERS MUST CORRESPOND WITH THE TECHNICAL STANDARDS STATED IN **EN 50123-3** AS WELL AS **VDE 0115**.

The DC circuit breakers produced by FLOHE are capable of providing the specified on/off switching in both directions. This fulfils the requirements of excess voltage category 4 in accordance with EN 50124-1.

ISOLATOR

NT2-1-1P-man

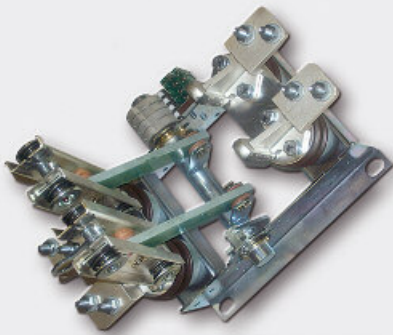

TECHNICAL DATA

Standard units (optional data on request)

Type	NT
Nominal current	0.4 up to 12 kA
Nominal voltage	0 up to 1.5 kV
Number of poles	1 up to 12 poles
Pole distance	variable
Peak withstand current	50 up to 200 kA
Withstand current	20 up to 85 kA/1 s resp. 3 s
Motor drive	24, 48, 60, 110, 220, 230 V AC/DC
Manual drive	manual lever, towing eye
Pneumatic drive	5-6 bar
Locking magnet	24, 48, 60, 110, 220, 230 V AC/DC

EARTHING SWITCH

GE50-24-1P-mot

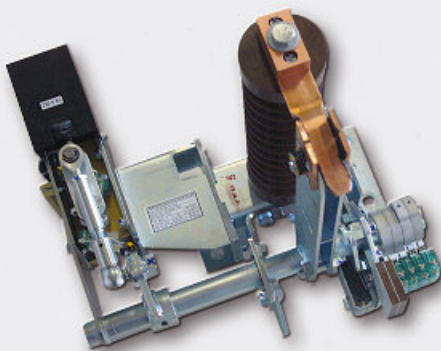

TECHNICAL DATA

Standard units (optional data on request)

Type	GE o. EES
Nominal voltage	0 up to 25 kV
Number of poles	1 up to 12 poles
Pole distance	variable
Peak withstand current	50 up to 200 kA
Withstand current	20 up to 85 kA/1 s resp. 3 s
Making capacity	50 up to 180 kA
Motor drive	24, 48, 60, 110, 220, 230 V AC/DC
Manual drive	manual lever, towing eye
Pneumatic drive	5-6 bar
Locking magnet	24, 48, 60, 110, 220, 230 V AC/DC
Construction type	E0, E1, E2

CHANGEOVER CONNECTOR

NT4-1,5-1P-U-mot

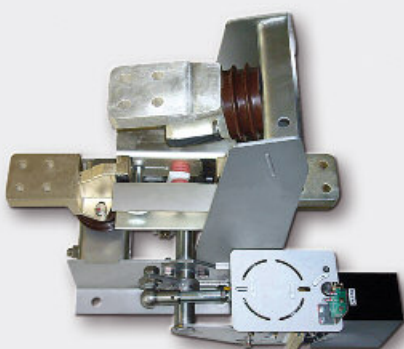

TECHNICAL DATA

Standard units (optional data on request)

Type	NT - U
Nominal current	0,4 up to 12 kA
Nominal voltage	0 up to 3,6 kV
Number of poles	1 up to 12 poles
Pole distance	variable
Peak withstand current	50 up to 200 kA
Withstand current	20 up to 85 kA/1 s resp. 3 s
Motor drive	24, 48, 60, 110, 220, 230 V AC/DC
Manual drive	manual lever
Pneumatic drive	5-6 bar
Locking magnet	24, 48, 60, 110, 220, 230 V AC/DC
Construction type	3 or more outgoing feeders (branches)

SWITCHGEARS FOR TRACTION

ISOLATORS · CHANGEOVER CONNECTORS
EARTHING SWITCHES · DC LOAD BREAKER



▶ Rail circuit work yard

▶▶ DC LOAD BREAKER ◀◀

FGML-4069-2010

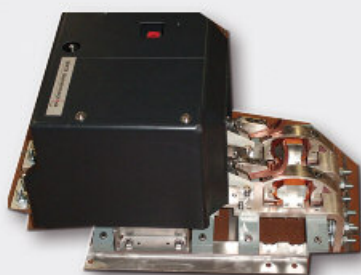

TECHNICAL DATA

Standard units (optional data on request)

Type	FGML
Nominal current	1 up to 6 kA DC
Nominal voltage	0 up to 1.5 kV
Number of poles	1 up to 12 poles
Pole distance	variable
Peak withstand current	50 up to 100 kA
Withstand current	20 up to 50 kA/1 s
Braking cap.	4800 – 10.000 A
Motor drive	24, 48, 60, 110, 220, 230 V AC/DC
Manual drive	lever



DC Load breaker
in outdoor cabinet

▶▶▶ WE ARE HAPPY TO OFFER YOU COMPLETE SOLUTION PACKAGES ◀◀◀

- These, for example, include outdoor barriers which can be used as supply or coupling points in the field of local railways.
- Of course, we are also able to offer these types of solutions as interior constructions.
- We are happy to work out special solutions according to your needs.

... GIVE US A CALL!

WHEN HIGH RELIABILITY AND OPERATIONAL SAFETY ARE NECESSARY.

- This level of reliability can also be provided under difficult climatic and technical conditions.
- It is often a good idea to combine various devices such as isolator / earthing devices or isolator / changeover switches with an earthing device.

STANDARD SIZE	
Earthing switch make proof	EES 1-2-3 ... 12 poles 3.6 - 7.2 - 12 - 24 - 36 kV
Earthing switch not make proof	GE 1-2-3 ... 12 poles 3.6 - 7.2 - 12 - 24 - 36 kV
Isolator	NT 1-2-3 ... 12 poles 1 kV up to 3.6 kV - 400 A - 12 kA GT 1-2-3 poles 3.6 bis 40.5 kV - 400 A - 12 kA
Changeover switch	NT 1-2-3 ... 12 poles U up to 3.6 kV GT 1-2-3 ... 12 poles U over 3.6 kV
Combi. Isolator/earthing switch	GE/NT
Special equipment	No. of poles · Pole distance · configur. of poles Switching angle · Auxiliary motor · auxiliary contact

LOW VOLTAGE

ISOLATOR

NT 2,5-3,6-2P-man

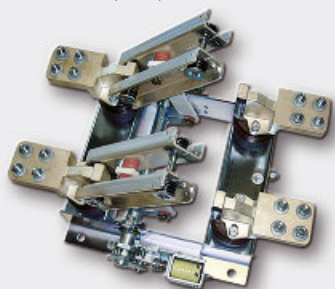

TECHNICAL DATA	Standard units (optional data on request)
Nominal current	0,4 up to 12 kA
Nominal voltage	0 up to 1,5 kV
Number of poles	1- up to 12-polig
Pole distance	variable
Peak withstand current	50 up to 200 kA
Withstand current	20 up to 85 kA/1 s resp. 3 s
Motor drive	24, 48, 60, 110, 220, 230 V AC/DC
Manual drive	manual lever, towing eye
Pneumatic drive	5-6 bar
Locking magnet	24, 48, 60, 110, 220, 230 V AC/DC

EARTHING SWITCH

EES 125/3,6-10/40-3/210-man

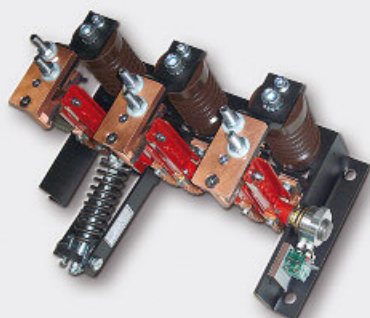

TECHNICAL DATA	Standard units (optional data on request)
Nominal voltage	0 up to 1,5 kV
Number of poles	1 up to 12 poles
Pole distance	variable
Peak withstand current	50 up to 200 kA
Withstand current	20 up to 85 kA/1 s resp. 3 s
Making capacity	50 up to 180 kA
Motor drive	24, 48, 60, 110, 220, 230 V AC/DC
Manual drive	manual lever, towing eye
Pneumatic drive	5-6 bar
Locking magnet	24, 48, 60, 110, 220, 230 V AC/DC
Construction type	E0, E1, E2

CHANGEOVER CONNECTOR

NT 3,15-3,6-3P-U-man

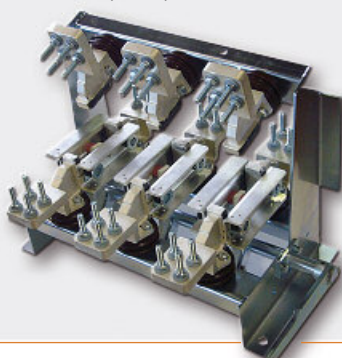

TECHNICAL DATA	Standard units (optional data on request)
Nominal current	0.4 up to 12 kA
Nominal voltage	0 up to 1.5 kV
Number of poles	1 up to 12 poles
Pole distance	variable
Peak withstand current	50 up to 200 kA
Withstand current	20 up to 85 kA/1 s resp. 3 s
Motor drive	24, 48, 60, 110, 220, 230 V AC/DC
Manual drive	manual lever, towing eye
Pneumatic drive	5-6 bar
Locking magnet	24, 48, 60, 110, 220, 230 V AC/DC
Construction type	3 or more outgoing feeders (branches)

LOW AND MEDIUM VOLTAGE

ISOLATOR SWITCHES · ISOLATOR / CHANGEOVER SWITCHES · EARTHING DEVICES

THESE ARE NEEDED WHEN WORKING ON ELECTRICAL EQUIPMENT SO THAT THE OPERATING PERSONAL CAN BE PROTECTED

MEDIUM VOLTAGE

ISOLATOR

GT 3,15-17,5-3P-mot

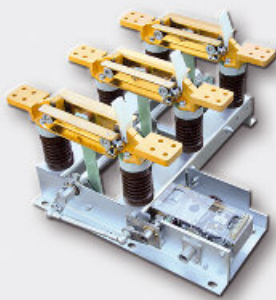

TECHNICAL DATA

Standard units (optional data on request)

Nominal current	0.4 up to 12 kA
Nominal voltage	1.5 up to 40.5 kV
Number of poles	1 up to 12 poles
Pole distance	variable
Peak withstand current	50 up to 200 kA
Withstand current	20 up to 85 kA/1 s resp. 3 s
Motor drive	24, 48, 60, 110, 220, 230 V AC/DC
Manual drive	manual lever, towing eye
Pneumatic drive	5-6 bar
Locking magnet	24, 48, 60, 110, 220, 230 V AC/DC

EARTHING SWITCH

EES 80/36-70/195-3/400-mot

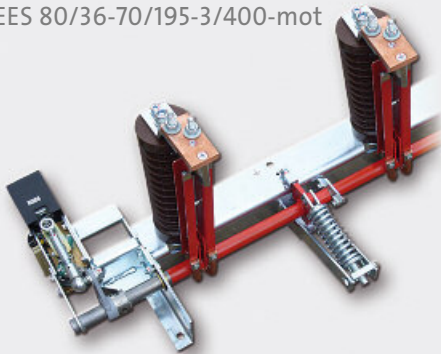

TECHNICAL DATA

Standard units (optional data on request)

Nominal voltage	1.5 up to 40.5 kV
Number of poles	1 up to 12 poles
Pole distance	variable
Peak withstand current	50 up to 200 kA
Withstand current	20 up to 85 kA/1 s resp. 3 s
Making capacity	50 up to 180 kA
Motor drive	24, 48, 60, 110, 220, 230 V AC/DC
Manual drive	manual lever, towing eye
Pneumatic drive	5-6 bar
Locking magnet	24, 48, 60, 110, 220, 230 V AC/DC
Construction type	E0, E1, E2

CHANGEOVER CONNECTOR

GT 0,63-3,6-5P-U-man

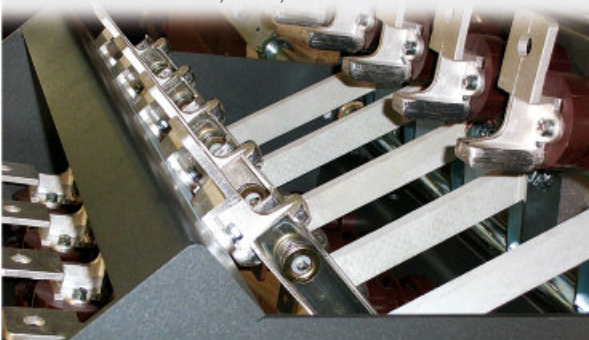

TECHNICAL DATA

Standard units (optional data on request)

Nominal current	0.4 up to 12 kA
Nominal voltage	1.5 up to 40.5 kV
Number of poles	1 up to 12 poles
Pole distance	variable
Peak withstand current	50 up to 200 kA
Withstand current	20 up to 85 kA/1s resp. 3s
Motor drive	24, 48, 60, 110, 220, 230 V AC/DC
Manual drive	manual lever, towing eye
Pneumatic drive	5-6 bar
Locking magnet	24, 48, 60, 110, 220, 230 V AC/DC
Construction type	3 or more outgoing feeder

PRODUCT OVERVIEW ...

FOR OVER 60 YEARS:
**COMPETENCE IN ENGINEERING
+ MANUFACTURING**

...FROM THE INDIVIDUAL COMPONENT
TO THE COMPLEX HIGH-CURRENT SYSTEM



▶ EAF / LF / ESU



▶ SUPPORT ARM TECHNOLOGY /
HIGH-CURRENT LINES



▶ HIGH-CURRENT CABLES



▶ EXPANSION JOINTS



▶ ELEKTROLYSIS:
BUSBARS



www.FLOHE.com



WE ARE HAPPY TO PROVIDE YOU
WITH ADVICE...

FLOHE
SCHALTGERÄTE GMBH

- ✉ RHEINSTRASSE 19
D-44579 CASTROP RAUXEL
- ☎ +49 (0) 2305 - 7003 - 0
- ☎ +49 (0) 2305 - 7003 - 199
- @ SWITCHGEAR@FLOHE.COM
WWW.FLOHE.COM



E.REDEKER

- ✉ LUISANT RING 16A
D-63477 MAINTAL
- ☎ +49 (0) 6181 - 9 45 83 10
+49 (0) 151 - 15 75 45 53 (MOBIL)
- ☎ +49 (0) 6181 - 9 45 83 11
- @ E.REDEKER@SWITCHCONTACTS.DE
WWW.SWITCHCONTACTS.DE